



## ***ELECTRIC PIZZA OVENS***

**CE**



Models: MS44 – MS66

**INSTALLATION OPERATING AND MAINTENANCE  
ISTRUCTIONS**

## **INTRODUCTION**

### **READ THIS ENTIRE MANUAL BEFORE UNPACKING AND INSTALLING THIS PRODUCT.**

Dear client,

Thank you for choosing a quality product manufactured by us.

Our expert production follows the guiding principle of the strictest quality control of each component so as to guarantee that our products will function efficiently far into the future. The mechanical, electrical, and electronic parts were designed and manufactured to guarantee reliability and high-quality functioning.

The use of parts that are not original could cause functioning problems or damage to the product. Therefore, always ask for any spare parts from authorized dealers to return the product to perfect working order and to guarantee that it will last longer.

All the machines we manufacture are made using modern technology and systems of tested reliability. We systematically referred to the current standards and regulations for mechanical products, specifically the UNI standards and the CEI standards for electric and electronic equipment. The units that are described in this manual, like all our products, are manufactured according to criteria of good practice and in strict compliance with the European directives and related regulations.

#### **Note:**

**The unit that is illustrated or described could be different from your unit for commercial or technical reasons, depending on the standards and safety regulations in force in the different countries in Europe and in the world. The technical specifications and dimensions, the described functioning, and any equipment cited are not binding. The figures show a generic unit only for illustrative purposes.**

**Before operating on the machine, read carefully the technical instructions included in this manual and follow the indications described.**



**Keep this manual and all the annexed literature in a readily accessible place and known to all the users (operators and maintenance personnel).**



## GENERAL TABLE OF CONTENTS

ENG

### **Section 1: General information - Instructions**

- 1.1- Introduction and safety recommendations
  - 1.1.1 - Residual risks
- 1.2 - Machine data and use
  - 1.2.1 - Application sectors
- 1.3- EC Declaration of Conformity
- 1.4 - Technical specifications
- 1.5- Machine description
- 1.6- Packing and standard equipment
  - 1.6.1 - Accessories available on request
- 1.7 - Safety devices
  - 1.7.1 - Operator safety
  - 1.7.2 - Safety devices of electric equipment - Wiring diagram
  - 1.7.3 - Safety devices of mechanical equipment

### **Section 2: Installing the machine**

- 2.1 - Unpacking
- 2.2 - Position in place
  - 2.2.1 - Assembly of the stand
- 2.3 - Connection to the electrical power supply
- 2.4 - Preliminary installation requirements
  - 2.4.1 - Technical information reserved to the qualified installer

### **Section 3: Intended use of machine**

- 3.1 - Controls descriptions
- 3.2 - Machine start-up
- 3.3 - Periodic use of the oven
- 3.4 - Cleaning the machine
- 3.5 - Regular maintenance
- 3.6 - Troubleshooting
- 3.7 - Long inactivity periods
- 3.8 - Disposal

### **Section 4: Spare parts - Electric Diagram**

- 4.1 - List of spare parts
- 4.2 - Connecting diagram

### **Appendix**

Warranty terms

## SECTION 1



### GENERAL INFORMATION - INSTRUCTIONS

ENG

#### 1.1 Introduction and safety recommendations

These operating and maintenance instructions are intended to operators and qualified personnel for the correct use of the machine.

In order to facilitate understanding of the content of this manual, we provide a list of terms and symbols used:

<b>Definition - Symbol</b>	<b>Description</b>
<i>Danger Zone</i>	Any area within and/or around the machine in which an exposed person is subject to a risk to his health or safety.
<i>Exposed Person</i>	Any person who is wholly or partially in a danger zone.
<i>Operator</i>	Person in charge of installing, operating, adjusting, servicing and cleaning the machine.
	Provides significant information.
	Indicates a potentially hazardous situation that may arise if the operations described are not carried out correctly, and which may result in damage to the machine and/or serious injury to operators.

Warnings of precautions and safety are written in this manual in order to remind the operator and staff on the possible dangers due to improper use of this machine.

The instructions or the warnings do not want to substitute the safe working practice but to complete them and to stimulate their compliance.



**Only warning does not eliminate the hazard.**

**Failure to observe this safety recommendations and improper use of the device may pose risk of accidents for the operator or other people.**



**1.1.1 Residual risks**

Safety, as far as possible, has been integrated in the design and construction of the machine, however risks remain from which the operators must be especially protected during maintenance, installation, production and cleaning:

- Do not place your bare hands or any part of the body on the hot parts of the oven or near the doors of the baking chambers.
- Do not put hands or arms or other body parts inside the oven. To open the door use the insulated handle.
- Do not put in the oven food packaging such as sealed metal cans or other material as it may explode due to high temperature with serious consequences for both the machine and the operator.



**1.2 Machine data and use**

The manual describes the operating instructions for electric ovens for pizzeria mod. MS44, MS66.



Our electric pizza ovens have been designed for baking of pizza and similar products in a simple and fast way, with the right temperature, ensuring the fragrance that was once the prerogative only of the traditional wood-fired cooking.

The model identification plate, placed at the rear part of the machine, next to the power line is as follows:

**47813 Bellaria - Igea Marina (ITALY)**

<b>Model:</b> _____			
<b>Serial Nr. 1055/04895</b>	<b>Year 2010</b>		
___ Volt	_ N~		___ kW
<b>50 Hz</b>			___ Kg

### 1.2.1 Application sectors

Electric ovens of our production are available in models of different sizes to meet the diverse needs of professional customers, such as:

- the kitchens of restaurants, institutions, cafeterias, pizzerias, etc..
- wherever it is necessary to cook preparations of flour for human consumption type, shape and texture similar to pizza.

### 1.3 EC Declaration of Conformity

**DICHIARAZIONE DI CONFORMITÀ / CERTIFICATE OF COMPLIANCE  
DECLARATION DE CONFORMITÉ / KONFORMITÄT SERLÄRUNG  
DECLARATION DE CONFORMIDAD**

**CE**

DESCRIZIONE DELLA MACCHINA / MACHINE DESCRIPTION / DESCRIPTION DE LA MACHINE / MASCHINENBESCHREIBUNG /  
DESCRIPTION DE LA MAQUINA:

FORNO ELETTRICO PER PIZZA / ELECTRIC PIZZA-OVEN / FOUR ÉLECTRIQUE À PIZZA / ELEKTRISCHE PIZZAFÖHN / HORNO ELÉCTRICO PARA PIZZA

MARCA / MAKE / MARQUE / MARKE / MARCA :

**GAM INTERNATIONAL SRL - Via Sile, 25/30 - z. artigianale - 47514 Bellaria Igea Marina (RN) - ITALY**

Il Sig. Lorenzo Giovagnoli (Via Sile, 25/30 - 47514 Bellaria Igea Marina (RN) è autorizzato a costituire il fascicolo tecnico pertinente.  
M. Lorenzo Giovagnoli (Via Sile, 25/30 - 47514 Bellaria Igea Marina (RN) is authorized to compile the technical file according to Annex VII A.  
Monsieur Lorenzo Giovagnoli (Via Sile, 25/30 - 47514 Bellaria Igea Marina (RN) est autorisé à constituer le dossier technique.  
Herr Lorenzo Giovagnoli (Via Sile, 25/30 - 47514 Bellaria Igea Marina (RN) ist bevollmächtigt, die technischen Unterlagen zusammenzustellen.  
Sr. Lorenzo Giovagnoli (Via Sile, 25/30 - 47514 Bellaria Igea Marina (RN) posee el poder para constituir la documentación técnica.

TIPO / MODEL / TYPE / TYPE / TIPO :

ALIMENTAZIONE ELETTRICA/ POWER SUPPLY / ALIMENTATION ÉLECTRIQUE / VERSORUNG / ALIMENTACION ELECTRICA

NUMERO DI SERIE / SERIAL NUMBER / NUMERO DE SERIE / SERIENNUMMER / NUMERO DE SERIE (S/N) :

ANNO DI FABBRICAZIONE / YEAR OF PRODUCTION / ANNEE DE PRODUCTION / BAUJAHR / AÑO DE FABRICACIÓN :

DIRETTIVE DI RIFERIMENTO E SUCCESSIVI AGGIORNAMENTI / REFERENCE DIRECTIVES AND SUBSEQUENT UPDATES /  
DIRECTIVES DE RÉFÉRENCE ET MODIFICATIONS ULTÉRIEURES / ÖLTFENDE RICHTLINIEN UND SPÄTERE ÄNDERUNGEN  
/ DIRECTIVAS DE REFERENCIA Y SUCESIVAS ACTUALIZACIONES :

- GESTIONE RIFIUTI RAEE / WASTE MANAGEMENT RAEE / GESTION REBUT RAEE / ABFALLBETUNG RAEE / GESTION BASURAS RAEE 2002/96/CE
- DIRETTIVA RoHS2 / DIRECTIVE RoHS2 / DIRECTIVE RoHS2 / RICHTLINIE / DIRECTIVA RoHS2 2002/95/CE
- MACCHINE / MACHINERY / MACHINES / MASCHINENRICHTLINIE / MAQUINAS 2006/42/CE (ex 90/269/CE)
- COMPATIBILITÀ ELETTROMAGNETICA / ELECTROMAGNETIC COMPATIBILITY / COMPATIBILITE ELECTROMAGNETIQUE / ELEKTROMAGNETISCHE VERTRÄGLICHKEIT / COMPATIBILIDAD AD ELECTROMAGNETICA 2004/103/CE
- BASSA TENSIONE / LOW TENSION / BASSE TENSION / NIEDERSPANNUNG / BAJA TENSION 2006/68/CE
- MATERIALI A CONTATTO CON PRODOTTI ALIMENTARI / MATERIALS IN CONTACT WITH FOODSTUFFS / MATERIAUX EN CONTACT AVEC PRODUITS ALIMENTAIRES / MIT LEBENSMITTEL IN BERÜHRUNG OBLANGENDE MATERIALIEN / MATERIALES EN CONTACTO CON PRODUCTOS ALIMENTICIOS 1936/2004/CE
- SICUREZZA IGIENE ALIMENTARE / FOOD HYGIENE SAFETY / SECURITE HYGIENE ALIMENTAIRE / LEBENSMITTELHYGIENE/SICHERHEIT / SEGURIDAD HIGIENE ALIMENTARIA 853/2004/CE

TENUTO CONTO DI QUANTO ESPOSTO NELLE "ISTRUZIONI PER L'USO", DICHIARO SOTTO LA MIA ESCLUSIVA RESPONSABILITÀ CHE LA MACCHINA SOPRA IDENTIFICATA COME OGGETTO DELLA PRESENTE DICHIARAZIONE È CONFORME ALLE PRESCRIZIONI DELLE DIRETTIVE CE SOPRAELENCATE // IN CONSIDERATION OF THE CONTENTS OF THE "INSTRUCTIONS FOR USE", I DECLARE UNDER MY OWN SOLE RESPONSIBILITY THAT THE MACHINE IDENTIFIED ABOVE AS THE OBJECT OF THE CERTIFICATE COMPLIES WITH THE REQUIREMENTS OF THE ABOVE QUOTED CE DIRECTIVES / SUR LA BASE DES INSTRUCTIONS D'UTILISATION, JE SOUS-SIGNE "NOTICE D'UTILISATION", DECLARE SOUS MON ENTIERE RESPONSABILITE QUE LA MACHINE SPECIFIEE CI-DESSUS FAISANT L'OBJET DE LA PRESENTE DECLARATION EST CONFORME AUX PRESCRIPTIONS DES DIRECTIVES SUSMENTIONNEES / AUFRUND DER IN DER BETRIEBANLEITUNG ENTHALTENEN ANWISSEN ERKLÄRE ICH AUF EIGENE VERANTWORTUNG, DAS DIE VORGESCHRIBENE MASCHINE ALS GEGENSTAND DER VORGESCHENEN KONFORMITÄTSEKLÄRUNG MIT DEN VORSCHRIFTEN IN DEN AUFGEFÜHRTEN RICHTLINIEN KONFORM IST / CONSIDERANDO LO EXPUESTO EN LAS "INSTRUCCIONES PARA EL USO", DECLARO BAJO MI EXCLUSIVA RESPONSABILIDAD QUE LA MAQUINA ANTES IDENTIFICADA COMO OBJETO DE LA PRESENTE DECLARACION SE AJUSTA A LO DISPUESTO POR LAS NORMAS DE LAS DIRECTIVAS PRECEDENTEMENTE SEÑALADAS.

Bellaria - Igea Marina (RN) :

**GAM International srl**

Administratore / Managing Director / Administrateur / Geschäftsführer / Administrador:  
*[Signature]*

FORNO ELETTRICO PER PIZZA / ELECTRIC PIZZA-OVEN / FOUR ÉLECTRIQUE À PIZZA / ELEKTRISCHE PIZZAFÖHN / HORNO ELÉCTRICO PARA PIZZA



#### 1.4 Technical specifications

MODEL		MS44	MS66
POWER SUPPLY	Volt	400V AC3/N/PE 230V AC1/N/PE	400V AC3/N/PE 230V AC1/N/PE
WORKING THERMOSTAT	°C	60-450	60-450
CHAMBER INTERNAL DIMENSIONS	mm	700x700x145	700x1050x145
CHAMBER INTERNAL DIMENSIONS TOP	mm	670x685x145	670x1035x145
EXTERNAL DIMENSIONS	mm	1010x1120x770	1010x1470x770
ABSORPTION	kW	9,6	14,4
NET WEIGHT	Kg	142	193
NET WEIGHT TOP	Kg	178	243
STAND	mm	1010x850x910	1010x1200x910
DIMENSIONS PACKING	mm	1150x1240x870	1150x1590x870
NEUTRAL UNIT	Mm / Kg	1010X970X70 / 11	1010X1320X70 / 13

All models have a working temperature ranging from 60 ° C to 450 ° C



Specifications, dimensions, performance, accessories and other data provided in this publication and business documentation are indicative and not binding on the manufacturer and therefore are subject to change without notice and without incurring any obligation.

### 1.5 Machine description

ENG

The machine consist mainly of the following groups:

1. **Control panel**
2. **Internal baking surface**
3. **Door + handle**
4. **Neutral unit (or extractor hood)**
5. **Valve for smoke discharge**



#### The main features are:

External structure made entirely of stainless steel. Cooking surface made of refractory material suitable for food use. Circular nozzle for venting fumes and smoke in the kitchen connected by suitable tubing (not supplied) to the chimney outside. Integral insulation of the baking chamber with insulating material for high temperature. Electric armored heating elements of durable high-quality materials. Single-phase power supply (230V) or three-phase (400V) AC at 50/60 Hz with tolerances according to CEI 8-6 of 3 / 1990. Adequate internal lighting to monitor the cooking cycle. Door equipped with spring hinges that can be easily removed for maintenance and cleaning.

### 1.6 Packaging and standard equipment

In order to avoid any damage during handling or transport, the machines are supplied with:

Type of packaging	Objective
Box of heavy corrugated cardboard	Protection against careless impacts and movements
Anti-static PVC bag	Protection against dust



protective casing made of elements of semi-rigid expanded polystyrene placed outside and inside the internal room.

Internal stability, impact protection and locking flat refractory

The packaging of all the models is secured to a wooden support (pallet) so that they can be perfectly handled with lifting means/transport.





The standard equipment of all the models consists of the following:

- ▶ An operations and maintenance instructions manual
- ▶ A catalogue of spare parts with exploded diagram
- ▶ Warranty Certificate
- ▶ EC Declaration of Conformity



Only the price list and the order confirmation of Your machine certify the effective general configuration with standard equipment and accessories.

### 1.6.1 Accessories available on request

Accessory	Image
Stand ( see section 2.2.1 for assembly). It is the natural support for pizza oven. It is designed to overlay the oven. It can be equipped with wheels for easy moving.	
Baking tins' holder: it is necessary to rearrange the baking tins	
Neutral unit	
Extractor hood	

Leavening cell



### 1.7 Safety devices

In order to ensure observance of the Essential Safety and Health Protection Requirements (ESHRs), all our products comply with the requirements of the following European Directives:

- ▶ Electrical Safety Directive (2006/95/EC).
- ▶ Electromagnetic Compatibility Directive (2004/108/EC).
- ▶ Machine Directive (2006/42/EC).

and include the criteria and the suitable devices that ensure all the provisions.



All the protection and safety devices of the machine and the equipment installed and all the signs that indicate danger, or provide information or recommendations must be kept in good conditions in their corresponding places.



**To tamper, modify or change the elements of the machine and the safety devices constitute fraudulent actions and bear civil and penal responsibilities for any direct or indirect damage to people, animals, objects or the environment.**

#### 1.7.1 Operator safety

The operators must:

- reach the age foreseen by the social laws,
- have good general competence and manual ability for coordination and be precise;
- have received proper technical and practical preparation (training) from an skilled operator;
- be aware of the dangers that derive from an improper use of the machine or from carrying out the prescriptions of this manual in a different way;
- wear personal protection equipment (thermal insulation gloves, glasses, masks, etc.) in compliance with the safety legislation and regulations in force in the



respective country, as prescribed by Directive 89/391/EEC and annexed directives.

### **1.7.2 Safety devices of the electrical equipment – Wiring diagram**

The electrical equipment of a machine designed and prepared following the EN - CEI standards already mentioned, as being of class I, is configured as follows:

- Control panel for electronic and control the temperature of the baking chamber: Armored heating elements with outer tube made of stainless steel AISI 321 annealed with neutral zone of 10 mm for the reduction of heat conduction to the supports. Heating element in nickel chrome 80/20. MgO ceramic insulation.
- terminal connection and derivation installed inside the compartment containing the equipment for command and control, general wiring connecting devices of the circuit unit, made of cables suitable for harsh operating conditions and proper-voltage limit.

The wiring diagram has been carried out according to the standard instructions related to the electric equipments of industrial machines.



There is a copy of the wiring diagram in the appendix of this manual.

### **1.7.3 Safety devices of the mechanical equipment**

The mechanical safety devices, to achieve the highest degree of safety and reliability are built into the machine and made inviolable:

- The door, with double glass with air space for air flow in an optimal operating range (up to around 330 ° C), is kept within limits of temperature that guarantee the total security from risk of burns.
- A hinge system release, with spring, allows to extract a few seconds the door for any necessary cleaning and / or maintenance.



## SECTION 2

### INSTALLING THE MACHINE

ENG

#### 2.1 Unpacking

Normally unpacking involves:

Step	Action	
1	Remove the fastening strap from the cardboard box and the wooden bedplate (pallet) by using a suitable tool (pair of scissors, cutter, etc).	
2	Introduce the point of a screwdriver between the cardboard and the points that fasten the lower part of the packaging and remove them by pulling outwards.	
3	Remove the upper cover of the cardboard packaging.	
4	Take away the anti-static PVC bag and the expanded polystyrene.	
5	Unscrew the "L" elements around the machine.	
6	Open the packaging completely and introduce the ropes and the lifting belts under the bedplate, towards both ends (make sure the capacity of the ropes are adequate for the weight of the machine). <b>Adjust the ropes or the belts so that all the lifting points are wrapped around and there is no chance that they slip off and the weight loses its balance.</b>	
7	Carefully sling the machine by protecting the parts of the structure that make direct contact with the lifting ropes/belts.	
8	Lift the machine from the wooden bedplate (pallet) and unload it in the allotted site on the ground.	

<b>9</b>	If necessary, use a soft and dry cloth to clean the outside part.
<b>10</b>	proceed with the removal of the boards of polystyrene designed to protect the refractory tiles.



**The machine must be handled only by personnel who are trained and familiar with the risks and the procedures related to unpacking, lifting and correct handling.**  
**Lift only by the help of suitable mechanical means. Absolutely ruled out lifting and manual handling.**

## 2.2 Position in place

To position the machine in place proceed as follows:

Step	Action
<b>1</b>	<b>Place the oven:</b> in an appropriate area and protected from the weather, considering in addition to its space also the one required for containers of raw materials and processed product. In a space effectively lit and large enough. In a place protected from sources of moisture or water faucet.
<b>2</b>	Consider the space around a minimum of not less than 50 cm for the proper ventilation, cleaning and maintenance purposes.
<b>3</b>	Verify that the proximity of the area you have a system capable of distributing electricity to the power of the machine (230V or 400V)
<b>4</b>	Place the base of the oven and the feet of the stand on a solid, uniform, well-polished, flat surface. The stand (par. 2.2.1) doesn't require anchoring to the ground, possibly normalize the unit using the screws M12: <ul style="list-style-type: none"> <li>• put a level on the oven first longitudinally then transversely;</li> <li>• block the screws once you reached the leveling.</li> </ul>



<p><b>5</b></p>	<p>The oven does not require any kind of attachment to the work surface on which it lies. If the oven is placed on a stand or leavening cell, make sure the latches are fully inserted on mounting holes on the stand or on the roof of the cell and that they are placed on the appropriate holes at the bottom of the oven itself.</p>	
<p><b>6</b></p>	<p>Proceed with the positioning, if provided, of the neutral unit or the extractor hood.</p>	

### 2.2.1 Assembly of the stand

#### List of the components:

4 square sections - legs (1, 2, 3, 4)

1 shelf for low position (9)

2 front sections (5, 6)

24 fastening screws, M 8 x 15

2 lateral sections (7, 8)

4 leveling screws, M12 x 50

24 nuts, M 8

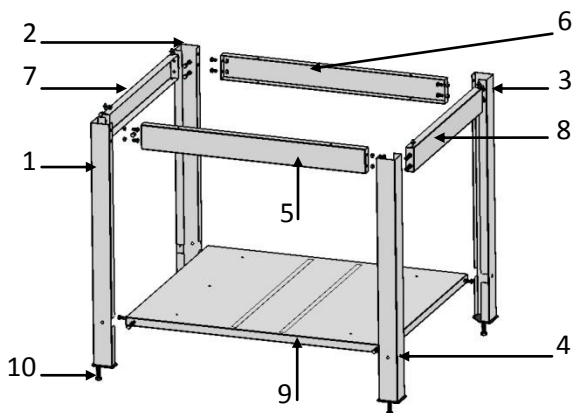

- Temporarily attach the legs (1, 2, 3, 4) to the sheet-metal shelf by placing the screws (A) in the lowest hole, as shown in the figure, and then screw on the nuts without tightening them completely.
- Attach the short sections (5, 6) to the legs by placing the screws in the upper holes.
- Attach the long lateral sections (7, 8) to the legs by means of the proper screws.
- At the ends of the legs adjust the four leveling screws (B) so as to level the unit well even on uneven surfaces.
- Proceed to finish tightening the screws while using a square or a level to check that the legs are in a perpendicular position and that the shelf is level. Tighten all the screws very well.

### 2.3 Connection to the electrical power supply



**The electrical connection to the power supply and the operation of the machine must be done, pursuant to the law, only by a qualified technician, who will previously check (IEC standards), with suitable means and tools, the effectiveness of the ground electrodes and the earthing system to which the device will be connected.**

**For installations outside the national territory, observe strictly the regulations in force in the country where the machine will be used.**

Make the connection following the provided technical manners, respecting both the cyclic sequence of phases of connection, and the color coding of conductors.

- ▶ L1 – fase
- ▶ L2 – fase
- ▶ L3 – fase
- ▶ N/MP – Neutro (colore AZZURRO)
- ▶ PE/Terra = Conduttore di protezione (colore GIALLO/VERDE a strisce)

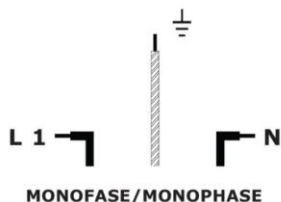



Protection against overcurrent and differential protection must be installed upstream of the connected equipment by the user.

ENG

## 2.4 Preliminary installation requirements

Install the machine only after you have checked that:

- ▶ the voltage indicated on the plate is the voltage the machine will be supplied with;
- ▶ the voltage and absorbed power characteristics of each machine model (Sec. 1.4) are suitable for the available voltage and power;
- ▶ the distribution system has an effective earthing system and safety switch.

All the components and materials necessary to perform the installation must: be done in full compliance with the laws in force and abide by the dictates of the low voltage directive and the electromagnetic compatibility directive in force.



**Keep in perfect condition and adequately protect against any damage the cable, the plug connection of the oven and all protective equipment and isolation of the power distribution box of the oven itself.**

### 2.4.1 Technical information reserved to the qualified installer



**The following informations are aimed, only, at qualified technical staff.**

The specialist installer near the point of installation of the oven, must:

- Place a length of power cable near the unit so as to permit the installed power cable to reach the power socket (do not use extension cables to make this connection);
- Install a suitable interlocked socket of industrial type;
- Install a disconnection switch;
- Install a thermal disconnecter and differential switch whose sensitivity is suitable to the current leakage from the heating elements.



Once operating checks and inspections are finished, the installer will have to issue the Declaration of Conformity in compliance with the provisions of Act 46/90



## SECTION 3

### MACHINE USE

ENG

#### 3.1 Controls description

The electrical control panel is placed in front of the machine in an ergonomic position, and is configured as follows:

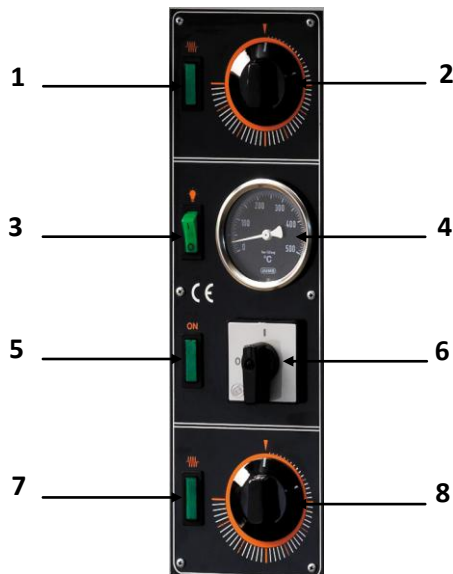

1. Indicator lamp of the upper deck
2. Control thermostat of the upper deck.
3. Power switch internal light chamber .
4. Temperature display
5. Indicator lamp net presence
6. Switch
7. Indicator lamp of the lower deck
8. Control thermostat of the lower deck.

### 3.2 Machine start-up

ENG

Before proceeding to use the oven for cooking food, it is necessary to adequately preheat the cooking compartment.

Step	Action
1	Insert the plug in the socket located on the shunt box
2	Make sure that the magnetothermic switch and the differential switch are both on.
3	Turn the power socket's disconnection switch to I/ON.
4	Turn the oven on and act on temperature commands of the cooking chamber at a temperature of about 250 ° C and maintain this temperature for about an hour. While the oven is being preheated, it will emit steam with an unpleasant smell. This is due to the surface oxidation of the annealed heating elements.
5	When the first cycle is completed, the metal will be stabilized and will no longer produce any unpleasant odor. While personally supervising the oven, open the front door and keep it open for several minutes so as to change the air in the oven more quickly, then close the door.
6	After the preheating phase has been performed, all the metal and refractory components in the cooking compartment will have reached the stabilization temperature and it will then be possible to normally use the oven. For subsequent use of the oven it will not be necessary to perform the above preheating cycle again.



The oven is equipped on the left side of the front (see par. 1.4) of a knob that, acting on a valve placed on the exhaust fumes, regulates the release of steam. During cooking, depending on the amount of steam produced, the location of this valve should be adjusted. To heat up the oven at full speed, it is recommended to keep the steam control valve tightly closed.

### 3.3 Periodic use of the oven

Before using the oven carry out the following check-outs and arrangements:

Step	Action
1	Insert the plug in the socket located on the shunt box
2	Make sure that the magnetothermic switch and the differential switch are both on.
3	Turn the power socket's disconnection switch to I/ON.
4	Turn the oven on and act on the thermostat of the baking chamber, setting the desired temperature (usually between 300 to 330 °C).
5	Wait for the oven to reach the desired temperature.
6	When the desired temperature is reached, open the door and place the pizzas in the oven. It is even possible to place them directly on the refractory material instead of on containers or pans.

It is recommended, in order to avoid thermal shock in the cell area and limit the consumption of energy, to open the door only for the time necessary to introduce or take out the pizzas or other food.



At the end of the production cycle, turn the oven off using the switch ON / OFF in the section “E” and turn on 0/OFF the switch / outlet line.



**Do not use the oven to heat or dry animals and similar.**

**The oven should not be used for any other purpose outside of those mentioned.**

### 3.3 Cleaning the machine

**Before carrying out cleaning (or maintenance) procedures:**

- Place the main switch to 0/OFF and disconnect the line by removing the plug from the socket;
- report the current operation by signboard;
- wait until the oven has cooled completely (it takes several hours)

**To clean adequately the:**

- Refractory bricks: Use a cloth dampened with only water or a brush with stiff bristles excluding any kind of detergent, solvent or chemical product (the high temperature reached provides the automatic sterilization of everything that is inside the oven).
- *Outside the machine:* Use a clean sponge with a small amount of adequate detergent and cleaning products.



Once cleaning operations of the different pieces of the machine are finished, refit them in their initial position and make sure they are correctly placed by tightening the corresponding fixing devices when necessary.



**Do not wash and/or clean:**

- I. by spraying water jets on the machine or its components;**
- II. Using abrasive cleaners, cream cleaners containing abrasives, solvents or diluents.**

**3.5 Regular maintenance**

If the machine is used as prescribed and indicated in this manual, the adequate manufacture of the mechanical pieces and the choice for suitable materials will allow the machine to operate with no faults and no need for maintenance for many years.

Whenever regular maintenance operation is performed on the machine, make sure that the machine is not connected to the mains (cable disconnected and green warning light off).

Perform at least every 15 days, the control on the efficiency of the switch circuit breaker, located on the power circuit of the oven by pressing the test button.

**3.6 Troubleshooting**

Problem	Probable cause	Recommended solution
Machine does not start	No power supply	<ul style="list-style-type: none"> <li>I. Check that the plug is properly connected;</li> <li>II. check that the thermo-magnetic switch has been activated ("ON");</li> <li>III. verify that the differential switch is active (if you press the "TEST" button and the lever remains still in high/upper position, this may indicate that there is no power);</li> </ul>



		<p>IV. check if there is power in other points close to the machine;</p> <p>V. have the machine installed by a duly trained technician.</p>
It doesn't reach the temperature	One or more heating elements interrupted	Have the machine installed by a duly trained technician.
Bottom or top doesn't heat	possible defects in a thermostat	Have the machine installed by a duly trained technician.



**In case of faults during operation, stop the machine, disconnect it from the mains and immediately contact a specialized technician.**



It is absolutely forbidden for the user to modify the machine for any reason. The manufacturer shall not be liable for any damages to people, animals, objects or the environment that may derive from:

- ▶ tampering with the machine;
- ▶ installation of not original spare parts;
- ▶ modifications to safety devices and systems;

carried out by the user or any other person not expressly authorized by the manufacturer.

### 3.7 Long inactivity periods

If the machine is not used for an extended period of time, it is compulsory to:

- Ensure careful cleaning and sanitizing
- Protect it from dust, taking care to leave the door ajar to prevent condensation from forming mounds or bad smells (avoid synthetic materials and bags).

### 3.8 Machine disposal

If the machine needs to be dismantled or destroyed, its parts are not as dangerous as to require the adoption of special precautions.

To facilitate material recycling, all the components of the electrical system, the thermoplastic components and the drive belts of the machine must be separated.

**USER INFORMATION – pursuant to art. 13 of the Legislative Decree No 151 of July 25<sup>th</sup>, 2005, “Implementation of Directives 2002/95/EC, 2002/96/EC and 2003/108/EC, on the reduction of use of hazardous substances in electrical and electronic equipment, as well as waste disposal”.**

The appliance and packaging are marked with the crossed-out dust bin symbol, which indicates that the product must be collected separately from other waste at the end of its lifetime.



Adequate separated collection of waste for later recycling, treatment and environmentally-friendly disposal is an important contribution towards avoiding a negative impact on the environment and health, and it also facilitates the recycling and/or re-use of the appliance's components.

Users who dispose of products in an unauthorised manner shall be liable for administrative penalties in compliance with the legislation in force.

Registration in the electrical and electronic material manufacturer's register with the **number: IT0803000004407.**

**Warranty conditions**

1) The manufacturer guarantees the operation and the duration of the products it manufactures. These products were built in a professional manner and underwent a functioning test in the manufacturer's workshop according to the specifications listed on the information plate and according to the theoretical normal working conditions. This warranty is valid for 12 (twelve) months from the date of purchase which is listed on the delivery documents or which can be deduced from the receipt issued by the dealer.

2) The warranty covers all the unit's components except for the electrical parts, the plastic parts and other fragile parts, the knobs, the removable parts, the painting and the chromium plating, and any accessories, since their condition depends directly on the user's care. The following are also not covered by the warranty: all damage caused by carelessness when transporting or handling the product, by negligence or incompetence when using the machine, by incorrect or bad installation or maintenance, by an inadequate electrical system to which the machine is connected, and by tampering by unauthorized personnel and/or personnel who are not qualified to work on the machine in a professional manner, as well as for any other reason that does not depend on the manufacturer.

3) During the warranty period the manufacturer pledges, through the dealer that made the sale and according to what is stated in the previous paragraph, to replace or repair free of charge those parts that are defective due to original material defects or due to defects in workmanship. If on-site service is requested, the user must pay a fixed charge for service calls according to the local rates in force or according to the national industry rates. If the machine must be repaired at the factory, the user will be exclusively responsible for all transport costs. Any repairs performed during the warranty period will not extend it.

4) To be eligible for service under warranty, the user must exhibit the warranty certificate and the receipt or delivery document to validate the purchase date of the machine. These documents must be impeccably compiled and absolutely free of tampering, corrections, erasures, etc.

5) The manufacturer does not undertake any other responsibilities except for those regarding the replacement of parts found to be defective according to its own unquestionable judgment. No responsibility is undertaken for any damages to the client due to the machine not running, or due to the time necessary to perform any service under warranty.

6) The manufacturer acknowledges only the warranty conditions listed on this certificate. No one is authorized to modify them or to issue other verbal or written warranty conditions.

7) The Court of Manufacturer's Town will be the exclusive competent court for any dispute arising concerning the interpretation and/or the application of these warranty conditions. Italian law will be applied exclusively regarding all legal aspects.