

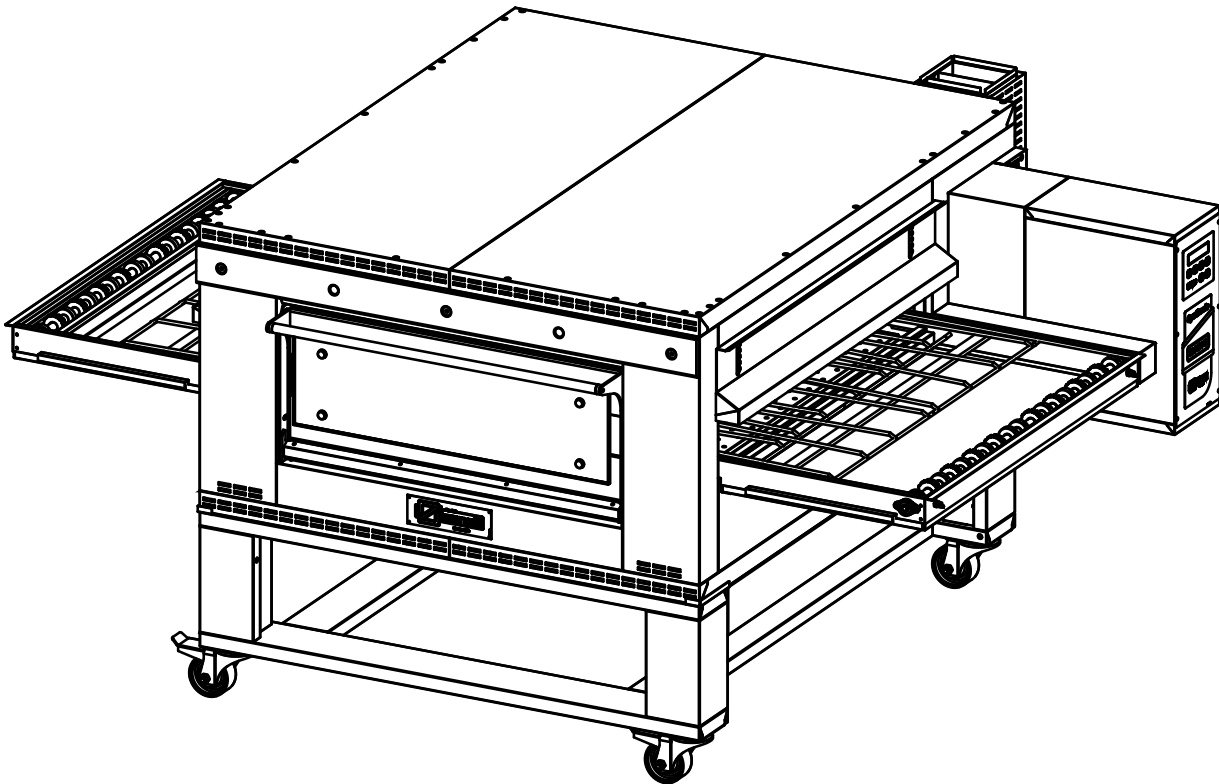

DR. ZANOLLI s.r.l.  
Via Casa Quindici, 22  
37066 Caselle di Sommacampagna (Verona) Italy  
Tel +39 045 8581500 (r.a.)  
Fax +39 045 8581455  
Web: [www.zanolli.it](http://www.zanolli.it) • e-mail: [zanolli@zanolli.it](mailto:zanolli@zanolli.it)



# SYNTHESIS 12/100V E

## Electric Conveyor oven

MANUAL FOR INSTALLATION, USE AND MAINTENANCE



**DICHIARAZIONE DI CONFORMITÀ  
DECLARATION OF CONFORMITY  
DECLARACIÓN DE CONFORMIDAD  
DÉCLARATION DE CONFORMITÉ  
KONFORMITÄTSERKLÄRUNG**



Noi  
We / El que suscribe /  
Nous / Wir

**Dr. ZANOLLI s.r.l.**  
**Via Casa Quindici, 22**  
**37066 Caselle di Sommacampagna, VR**

dichiaro sotto la nostra esclusiva responsabilità che l'apparecchiatura  
*declare under our responsibility that the equipment / declara bajo su propia responsabilidad que l'equipo /  
déclarons sous notre responsabilité que l'appareil / erklären in alleiniger Verantwortung, daß das Gerät*

**Marca** Dr. ZANOLLI s.r.l.  
*Manufactured by / Marca / Marque de fabrique / Bezeichnung*

**Modello**  
*Model / Modelo / Model / Modell*

**N° di serie**  
*Serial number / N° de serie / N° de série / Seriennummer*

**Anno di costruzione**  
*Year of construction / Año de construcción / Année de construction / Baujahr*

come descritto nella documentazione allegata, è in conformità con le seguenti direttive europee  
*is in conformity with the following European Directives / es conforme con las siguientes Directivas europeas /  
est conforme aux suivantes Directives européennes / auf das sich diese Erklärung bezieht, mit den E - Normen*

**- 2006/95/CE Direttiva Bassa Tensione**

*Low Tension Directive / Directiva Baja Tension / Directive Basse Tension / Niederspannungsrichtlinie*

**- 2004/108/CE Direttiva Compatibilità Elettromagnetica**

*Electromagnetic Compatibility Directive / Directiva Compatibilidad Electromagnetica /  
Directive Compatibilité Electromagnétique / Elektromagnetische Verträglichkeit*

**- 2006/42/CE Direttiva Macchine**

*Machines Directive / Directiva Maquinas / Directive Machines / Maschinenrichtlinie*

**- 1935/2004/CE Regolamento Oggetti destinati a venire in Contatto con i Prodotti Alimentari**

*Regulation for Equipment intended to come into Contact with Foodstuffs / Normativa para Equipos destinados a  
entrar en Contacto con Alimentos / Réglementation Objets destinés à venir en Contact avec des Produits  
Alimentaires / Gesetzliche Regelung der Gegenstände, die mit Lebensmitteln in Kontakt kommen*

**e con le norme cogenti alle direttive.**

*and with the compulsory regulations of the Directives / y con las normas ineludibles de las Directivas /  
et aux normes inéluctables des Directives / und mit den Zwangsvorschriften der Richtlinien, übereinstimmt*

Caselle di Sommacampagna

**Dr. Zanoli s.r.l.**  
**Collaudatore**  
*Tester / Ensayador / Testateur / Prüfer*

ALL. 7.2-C3 Dichiarazione di Conformità

Rev. 3 del 17/09/2013

**Dr. ZANOLLI s.r.l.**  
Via Casa Quindici, 22  
37066 Caselle di Sommacampagna (Verona) Italy  
Tel. + 39 045 8581500 (r.a.)  
Fax + 39 045 8581455  
web: [www.zanoli.it](http://www.zanoli.it) • e-mail: [zanoli@zanoli.it](mailto:zanoli@zanoli.it)

Capitale sociale € 93.600,00  
Reg. Imprese N. 3367  
Cod. Fisc./Part. IVA 00213620230  
Codice Comunitario IT 00213620230  
R.E.A. VERONA N. 57706  
Export M. VR005011



Dr. Zanolli s.r.l.  
Via Casa Quindici, 22  
37066 Caselle di Sommacampagna VR  
Tel. +39-0458581500 Fax +39-0458581455  
VAT N.IT00213620230

# INDEX

<b>1</b>	<b>INTRODUCTION .....</b>	<b>5</b>
<b>2</b>	<b>HOW TO USE THIS MANUAL .....</b>	<b>6</b>
<b>3</b>	<b>SPECIFICATIONS .....</b>	<b>8</b>
<b>3.1</b>	<b>PRODUCT IDENTIFICATION .....</b>	<b>8</b>
<b>3.2</b>	<b>CONFORMITY TO DIRECTIVES .....</b>	<b>8</b>
<b>3.3</b>	<b>ENVISAGED USE .....</b>	<b>8</b>
<b>3.4</b>	<b>TECHNICAL SPECIFICATIONS .....</b>	<b>9</b>
<b>4</b>	<b>INSTALLATION WARNINGS .....</b>	<b>10</b>
<b>4.1</b>	<b>DELIVERY CHECKS .....</b>	<b>10</b>
<b>5</b>	<b>INSTALLATION .....</b>	<b>11</b>
<b>5.1</b>	<b>CHOICE OF PLACE OF INSTALLATION .....</b>	<b>11</b>
<b>5.2</b>	<b>ELECTRICAL CONNECTION .....</b>	<b>11</b>
<b>6</b>	<b>OPERATION .....</b>	<b>14</b>
<b>6.1</b>	<b>CONTROL PANEL .....</b>	<b>14</b>
<b>6.2</b>	<b>FUNCTIONAL STATES OF THE SYSTEM .....</b>	<b>15</b>
6.2.1	Main on/off switch  .....	15
<b>6.3</b>	<b>SETTINGS .....</b>	<b>16</b>
6.3.1	Cooking time adjustment .....	16
6.3.2	Temperature adjustment .....	16
6.3.3	Top and bottom power adjustment .....	16
<b>6.4</b>	<b>PROGRAMMING .....</b>	<b>17</b>
6.4.1	Setting the current time .....	18
6.4.2	Setting the language .....	19
6.4.3	Programming of switching on .....	19
<b>6.5</b>	<b>SWITCHING OFF THE OVEN .....</b>	<b>20</b>

<b>6.6</b>	<b>SAFETY PROCEDURES.....</b>	<b>20</b>
6.6.1	“TEMP 1”.....	20
6.6.2	“TEMP 2”.....	20
6.6.3	“TEMP”.....	21
6.6.4	“MESH”.....	21
6.6.5.	"BATTERY".....	21
<b>7</b>	<b>USE .....</b>	<b>22</b>
<b>7.1</b>	<b>FIRST IGNITION.....</b>	<b>22</b>
<b>7.2</b>	<b>GENERAL COOKING INDICATIONS.....</b>	<b>23</b>
<b>7.3</b>	<b>SHORT PERIODS OF IDLENESS.....</b>	<b>23</b>
<b>7.4</b>	<b>EXTENDED PERIODS OF IDLENESS.....</b>	<b>23</b>
<b>8.</b>	<b>CLEANING .....</b>	<b>24</b>
<b>8.1</b>	<b>CLEANING OF ANY REMOVABLE PARTS .....</b>	<b>24</b>
<b>8.2</b>	<b>CLEANING OF EXTERNAL PARTS .....</b>	<b>24</b>
<b>8.3</b>	<b>CLEANING OF BAKING CHAMBER .....</b>	<b>24</b>
<b>9.</b>	<b>MAINTENANCE.....</b>	<b>26</b>
<b>9.1</b>	<b>ERROR WARNING.....</b>	<b>26</b>
<b>9.2</b>	<b>SAFETY THERMOSTAT .....</b>	<b>26</b>
<b>9.3</b>	<b>REPLACE BATTERY .....</b>	<b>26</b>
<b>9.4</b>	<b>WIRING DIAGRAM.....</b>	<b>28</b>
<b>9.4</b>	<b>EXPLODED VIEWS AND LIST OF SPARE PARTS.....</b>	<b>29</b>
<b>10.</b>	<b>DECOMISSIONING AND DEMOLITION .....</b>	<b>35</b>

# 1 INTRODUCTION

The **Synthesis 12/100V** version, is part of a family of conveyor belt ovens which have been primarily designed for the automatic cooking of pizzas and similar products. The special characteristic of the oven is that it is possible to carry out excellent cooking without the need to check on the cooking. The result is that the cooking processes can be put in the hands of unskilled staff.

These advantages are reinforced by the fact that the **Synthesis 12/100V** come into the family of ventilated ovens. The circulation of air in the cooking chamber means it is possible to achieve more even and repeatable cooking ,thus further simplifying the tasks of the operator. The **Synthesis 12/100V** is thus particularly efficient and by suitably controlling the air circulation the product will not dry out and retains all of its flavour.

The manufacturer thanks you for choosing one of our ovens. We can assure you that you have made a good choice as we have been making quality products for decades now and have never engaged in counterproductive penny-pinching in our selection of the best available materials.

## 2 HOW TO USE THIS MANUAL

 The paragraphs with this symbol contain essential safety information. They must all be read both by the installers and by the final user and any of his staff who may use the equipment. The manufacturer shall not be held liable for any damaged which may occur as a result of failure to observe the norms indicated in these paragraphs.

 The paragraphs with this symbol contain important information that can be used to avoid damage being caused to the equipment. It is the user's own interest also to read these paragraphs carefully.

 This manual should be kept near to the equipment itself so that it can be quickly and easily consulted. The manual must travel with the equipment if it is moved to another owner as the latter may not be considered complete or safe without it.

Please take note of the code and revision numbers which are behind the back cover. If this copy should get mislaid or destroyed you can order another one by referring to the codes.

 This manual is divided up into a number of chapters. All of these should be read by the installers, maintenance staff and the final user, both in relation to its **safe use** and in order to obtain the best results from this product.

Despite this we also give below some useful indications on how to look things up quickly in the various chapters.

**Chapter 3** contains a description of the oven's characteristics and all the figures which may be needed when choosing, installing and using it. It should be used as a reference to check the use which is intended to be made of the equipment corresponds to that for which it was designed, and whenever it is necessary to know an exact size value relating to the equipment.

**Chapters 4 and 5** provide all the information necessary for the installation of the oven. They have been primarily written for specialised staff but may be read in advance also by the final user to prepare and set up the space and plant necessary for the proper working of the equipment.



**Chapters 6 and 7** help the operator to switch on, use and switch off the oven in safety conditions.

**Chapter 7** includes use advices.

**Chapter 8** provides all the information required for the cleaning of the equipment i.e. all those operations which have to be carried out by the user in order to ensure that the equipment continues to function safely ( especially from the point of view of hygiene ) and generally obtains the best results at all times.

**Chapter 9** provides the information necessary for proper periodic and extraordinary maintenance e.g. repairing or replacing parts of the equipment.

This chapter has also an exploded view of the equipment and list of spare parts to make ordering and replacing any damaged part easier.

**Chapter 10** decommissioning and demolition.



These maintenance operations must be carried out by specialised staff.

## 3 SPECIFICATIONS

### 3.1 PRODUCT IDENTIFICATION

This is the manual for the conveyor belt oven Synthesis 12/100V E.

### 3.2 CONFORMITY TO DIRECTIVES

The Synthesis 12/100V E bear the following compulsory mark:

**CE** which indicate their conformity to the following European directives:

2006/95/CE Low Tension Directive

2004/108/CE Electromagnetic Compatibility Directive

2006/42/CE Machines Directive

1935/2004/CE Regulation for Equipment intended to come into Contact with Foodstuffs

### 3.3 ENVISAGED USE

The electric oven of a family Synthesis 12/100V have been designed to cook pizzas and similar products. The oven are intended for use in the catering industry (restaurant, pizzerias, etc.) and **for professional use by trained staff.**

The operations envisaged in normal use of the cooking modules are the loading and unloading of products from the cooking belt, switching on, regulation, switching off and cleaning of the whole equipment.

### 3.4 TECHNICAL SPECIFICATIONS

The table below show the technical specifications of the bake unit.

	<b>Synthesis 12/100V E</b>	<b>Unit of measure</b>
Weight	435	Kg
Weight with base	483	Kg
Overall dimensions	1845x2430x710	mm
Overall dimensions with base	1845x2430x1182	mm
Conveyor belt width	1010	mm
Conveyor belt length	2330	mm
Chamber length	1300	mm
Production capacity	180-220 (Ø 30 cm)	pizze/h
Electrical feed	Three-phase	
Voltage	400	Vac
Frequency	50 o 60	Hz
Current	73	A
Total electrical power	44	kW
Electrical connection	Plugless 5 lead cable	
Cable length	2	m
Section of lead wires	16	mm <sup>2</sup>
Temperature Control	Elettronico computerizzato	
Unit of measurement temperature	°C	
Maximum temperature which can be set	320	°C
Error warnings	By display	
Ambient conditions:		
Temperature	0 – 40 °C	
Maximun humidity	95% without condentation	

Tab. 3-1 Technical specifications.

## 4 INSTALLATION WARNINGS

 **WARNING:** These installation instructions are intended only for staff which is qualified for the installation and the maintenance of electrical and/or gas plant. Installation by any other person may cause damage to the equipment, persons, animals or things.

Furthermore where, to install the equipment, it is necessary to make any modifications or additions to the electrical plant in the building in which the equipment is being installed, the works must be certified as having been carried out in accordance with proper practice.

### 4.1 DELIVERY CHECKS

Unless otherwise agreed the products are carefully packed in a strong wooden crate with a blister sheet of nylon to protect them from shocks and humidity during transit and are delivered to the forwarder in the best possible condition.

We recommend, however, that the packaging is checked on arrival to ensure that there are not visible signs of damage. If there are any such signs indicate their nature on the receipt which has to be signed by the driver.

Once the equipment is unpacked check to see if it has suffered any damage. Also check that any parts which are delivered unattached to the equipment are present. If there has been any damage to the equipment and/or any parts are missing do not forget that the transport company will accept complain only up to 15 days from the delivery and that the manufacturer will not be held liable for damage suffered to its products during transit. We have nevertheless willing to help you in presenting your complaint.

 If there is any damage do not attempt to use the equipment and call upon professionally qualified staff.

## 5 INSTALLATION

### 5.1 CHOICE OF PLACE OF INSTALLATION

The good, safe and long working of the equipment also depends on the place in which it is installed so it is advisable to carefully evaluate this before it is delivered.

Install the equipment in a dry place which is easily accessible both as regards its use and its cleaning and maintenance. The area around the equipment must be free of encumbrances. In particular it is necessary to avoid obstructing the cooling apertures.

The equipment must in any case be installed at least 20 cm from the walls of the room and from other equipment.

 Finally it is necessary to ensure that the temperature and relative humidity of the place in which the equipment is installed must never exceed the maximum and minimum values indicated in the characteristics section (see 3.4). In particular if the maximum temperature and relative humidity are exceeding the equipment may easily and unpredictably go out of order or be damaged in its electrical parts, thus creating a dangerous situation.

### 5.2 ELECTRICAL CONNECTION

 The equipment is supplied with a cable for the electrical connection with earth lead. In observance of the current safety norms **it is compulsory to connect the earth wire (yellow-green) to an equipotential system whose efficiency must be properly checked against the norms currently in force.**

 Before making any connection ensure that the characteristics of the mains supply to which the equipment has to be connected, corresponds to the feed characteristics required by the equipment itself (see table 3-1).

The feed cable must end in a plug which connects to an electrical feed panel with a corresponding socket and a differential magneto thermal switch.

The plug-socket must be such that the earth lead is connected first and disconnected last and must be of the correct size for the nominal current (See table 3.1 ). Suitable plugs and sockets are the industrial type CEE17 of any which satisfy the European norm EN 60309.

The thermal safety device must be set for the total nominal current, the magnetic safety device must be set for the instantaneous maximum current ( in the case of ovens it is a little above the nominal figure) (see table 3.1 ), while the differential device must be set to the 30 mA current (see 3.).

The manufacturer shall not be liable for any damage which results from failure to observe the above mentioned norms.

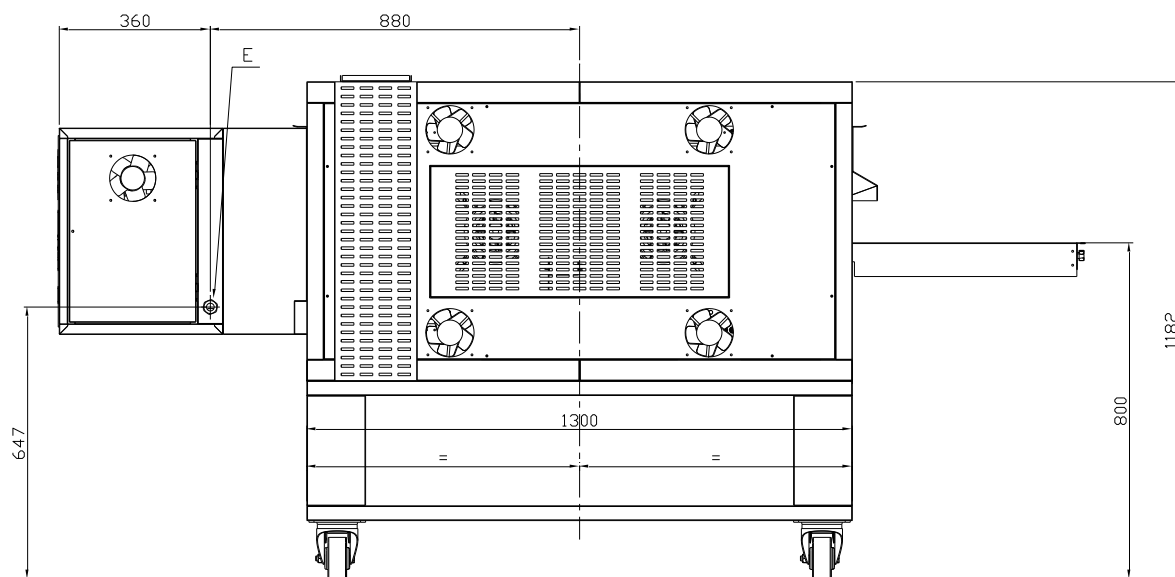



## 6 OPERATION

### 6.1 CONTROL PANEL

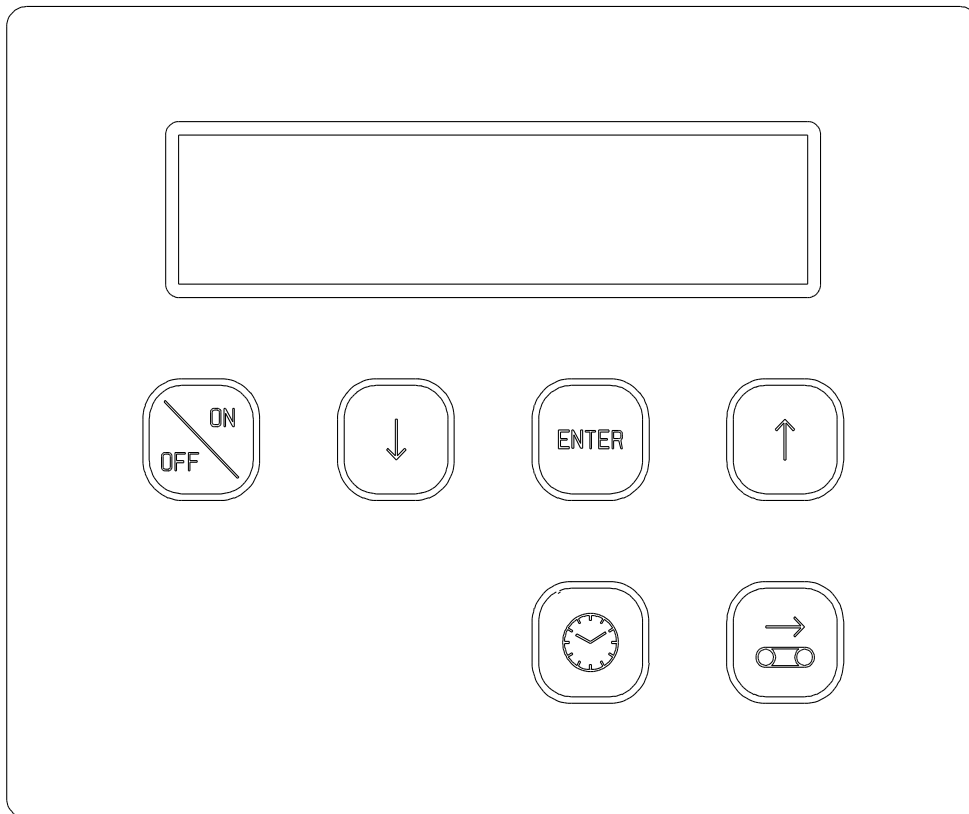

Oven on-off key



Parameter value decrease key



Programme access key



Parameter value increase key



Mesh start/stop key



Automatic switching on-off key



## 6.2 FUNCTIONAL STATES OF THE SYSTEM

### 6.2.1 Main on/off switch



In the off position there is power in the system but none of the individual functions work as the main contactor is deactivated.

All the outputs are de-energized except the ones for programming.

The display indicates "OFF", the current time and the day and time the oven will next be automatically switched on.

The day is written as follows:

OFF	00:MM
Start: ddd	oo:mm

where:

OO = current hour

MM = current minute

ddd oo:mm = day, time, minute the oven is automatically switched on.

The day is written as follows:

Monday

Tuesday

Wednesday

Thursday

Friday

Saturday

Sunday

When the oven is off, the rear illumination on the display is also off.

This turns on when programming is started.

In the ON position the main contactor is activated, the fan turns on and the oven heats up. The display is illuminated from behind and indicates:

XXX°C	mm:ss
■ CC%	PP% ■

where:

XXX°C = Cooking temperature

mm:ss = Cooking time in minutes and seconds

CC% =

PP% = Bottom heating elements

## 6.3 SETTINGS

### 6.3.1 Cooking time adjustment

The desired cooking time is set directly by the user, relating to the relative speed of mesh progress automatically controlled by the electronic circuit board.

When the oven is switched on, the mesh is inactive and the cooking time flashes on the display.

Press the mesh start/stop key  to activate the mesh.

Mesh movement can be activated or deactivated at any time using the key .

When the mesh is inactive, the cooking time flashes.

When the oven is on, the mesh can be manually adjusted to reach

maximum speed by pressing the key  for 4 seconds.

Press the same key again to return to the previous setting.

See the “programming” paragraph to set the cooking time.

### 6.3.2 Temperature adjustment

The oven temperature can only be adjusted when the oven is on.

The oven heats up to and then remains at the set temperature until it is switched off.

When the oven is on, the real temperature of the cooking chamber is

indicated; press the parameter value increase key  to display the set temperature.

See the “Programming” paragraph to learn how to adjust the set temperature.

### 6.3.3 Top and bottom power adjustment

To heat up of the oven , modulate the ignition of the top and bottom heating elements according to the selected power percentage, as explained hereunder.

The modulation consists in the ignition of the heating elements for a fixed time, on a period of 45 seconds in total.

For example if the value 20% is selected, the heating elements will be fed cyclically for 9 seconds each 45.

To avoid that heating elements are switched on at the same time, the top elements are on at the beginning of the period, while the bottom elements are on at the end.

For instance, if the value 30% is selected for the top heating elements, and the value 20% is selected for the bottom heating elements, the working cycle is effected as shown below:

4,5	9	13.5	18	22.5	27	31.5	36	40.5	45	<b>Sec.</b>
<b>ON</b>		<b>OFF</b>								<b>TOP</b>
<b>OFF</b>								<b>NO</b>		<b>BOTTOM</b>

On the display you can read the percentage of ignition of the heating elements (CC%=top heating elements, left / PP%=bottom heating elements, right)

XXX°C	mm:ss
■ CC%	PP% ■

When the heating elements are switched on, on the display the indicator (■) is shown.

If the value 0% is selected, the relevant group of heating elements never turns on.

See the paragraph "Programming" to learn how to set the power parameters of top and bottom heating elements and how to set the cooking time.

## 6.4 PROGRAMMING

The operating parameters programmed by the user are:

XXX°C	mm:ss
■ CC%	PP% ■



where:

- cooking time (mm:ss)
- set temperature (XXX°C)
- the percentage of ignition of top heating elements (CC%)
- the percentage of ignition of bottom heating elements (PP%)

These parameters are normally indicated on the display when the oven is on and can be set with the oven on or off.

Press the programming access key  to enter programming mode and move from one parameter to the next.

The parameter being programmed flashes on the display in a horizontal line at the bottom.

To change the value, use the keys  to increase and  to decrease. By keeping the key pressed you increase the speed of data change. If no key is pressed for more than 5 seconds, the displayed value is memorised and the oven automatically leaves the programming mode.

During programming the keys  and  are deactivated.

The order of programming is as follows:

- 1) Cooking time
- 2) Temperature
- 3) Top heating elements
- 4) Bottom heating elements

### 6.4.1 Setting the current time

The current time can be set by the user when the oven is on or off.

Press the key  for 3 consecutive seconds to access the setting.

The display indicates:

PROGRAM CLOCK GG-MM-AA oo:mm
---------------------------------

where:

GG = current day



MM = current month

AA = current year

oo = current hour

mm = current minute

A cursor indicates the data being modified.

The value can be adjusted using the keys  and . Then confirm by pressing the key  and move to the next item of data.

After setting the day, month, year, hour and minutes, press the key  to move to programming the current day of the week.

The following box:

PROGRAM CLOCK DDDDDDDD
---------------------------

appears on the display, where:

DDDDDDDDDD = current day of the week.

## 6.4.2 Setting the language

The display language can be chosen from a list of available options.

To set the language, enter the clock programming mode (see setting the clock) and confirm the data until appears on the display.



SELECT LANGUAGE  
ENGLISH









Adjust and confirm using the same procedure adopted for setting the clock. By confirming you leave the programming mode and return to the previous mode.



## 6.4.3 Programming of switching on

To access the settings for the programmed switching on, press and immediately release the key  with the oven on or off.

At first the state of the automatic switching on (active or inactive) appears on the display (AUTOSTART : ON or OFF).

Press the keys  or  to activate or deactivate the programmed switching on.

After activating with the key , press the key  and the day and time appear on the display. To select the switching on time, position the flashing cursor under the time using the key  and then press keys  or  to set the value. If the oven is not required to be switched on a certain day (e.g. closing day), select the off option between 23 and 00 while setting the time using the keys  or . Press the key  again to move to minutes and press the key  once again to bring the cursor back to the day of the week.

To move to the next or previous day press the keys  or .

When the setting is complete, press the key  again and wait for about five seconds. The data is automatically memorised and the oven returns to the previous function.

When the oven is off, the day and time of the switching on appears on the display to indicate that this function is on. The word "off" appears instead of the day and time if the function is not activated.

## 6.5 SWITCHING OFF THE OVEN

Press the key  to switch off the oven.

The heating stops while the air recycling fan and mesh continue working, if on, until the temperature drops below 150°C. After this the main contactor de-energizes leaving only the circuit board powered to feed the clock and programmed switching on functions.

During the switching off phase the rear illumination remains on and the word "OFF" flashes. During this phase the oven can be switched back on and the mesh can be started or stopped.

To prevent the oven being accidentally switched on, check the display indicates the precise desired day and time of switching on, or, if automatic switching on is not desired, that the words "start: off" appear.

## 6.6 SAFETY PROCEDURES

The functioning of the oven is continually checked, setting off an alarm procedure if any faults arise.

### 6.6.1 "TEMP 1"

If the temperature measured by probe 1 exceeds 350°C or if the probe breaks, the temperature value on the display is replaced by the flashing phrase "TEMP 1" and the alarm intermittently sounds.

Switch off the alarm by pressing the key .

The oven continues working and only probe 2 is used to measure the temperature. The control temperature is also automatically decreased by 40°C.

This variation in the temperature corrects the only value read in the hottest part of the oven and simulates an approximate value to the effective value which was previously set by supplying the average of values between the hottest and coldest points. This allows the oven to be used even when a probe breaks.

### 6.6.2 "TEMP 2"

If the temperature measured by probe 2 exceeds 450°C or if the probe breaks, the temperature value on the display is replaced by the flashing phrase "TEMP 2" and the alarm intermittently sounds.

Switch off the alarm by pressing the key .

The oven continues working and only probe 1 is used to measure the temperature. The control temperature is also automatically raised by 40°C.

This variation in the temperature corrects the only value read in the coldest part of the oven and simulates an approximate value to the effective value which was previously set by supplying the average of values between the hottest and coldest points. This allows the oven to be used even when a probe breaks.

### 6.6.3 "TEMP"

If the temperature measured by probe 1 exceeds 350°C and probe 2 exceeds 450°C at the same time, the temperature value on the display is replaced by the flashing word "TEMP" and the alarm sounds intermittently.

Switch off the alarm by pressing the key  .



### 6.6.4 "MESH"

When the mesh motor is broken or sends wrong signals to the circuit board, the word "RETE" ("MESH") flashes on the display and the alarm sounds intermittently. This means that the cooking time does not correspond to the set value and that specialized personnel are required to reset the functions of the oven.



### 6.6.5. "BATTERY"

When the buffer battery installed on the main electronic board is exhausted, an alarm is activated on the display together with the flashing writing "Battery" and the acoustic signal plays in intermittent way. To replace the battery see paragraph 9.3.



## 7 USE



 During cooking or at the end of cooking some of the oven's surfaces reach dangerous temperatures. The  symbol warns of this danger. Never touch these surfaces and only use the proper handle.



### 7.1 FIRST IGNITION



 Before connecting the oven to the electrical main, be sure that the main switch  is positioned on OFF.

Position the switch  on the ON position; the fan is activated.

Select the desired cooking time by pressing the push-button  then adjust it as required by pressing the push-buttons  and .

Now press the push-button  and select the desired temperature by means of the buttons  and  then confirm.

Select  to adjust the oven top power by means of the buttons  and , then confirm.

After having adjusted the top power, select  to adjust the bottom power by means of the buttons  and , then confirm.

After having chosen the cooking time and temperature, start the conveyor by pressing the relevant push-button .



---

## 7.2 GENERAL COOKING INDICATIONS

It is not possible to say exact times and temperatures for food products in general given the enormous variations they are subject to.

As regards pizzas and similar products in particular the cooking time and temperature depend on the shape and thickness of the dough and the quantities of the ingredients added to it.

We therefore advise that a few test runs are made, especially if you have never worked with this model of oven before, starting out with a temperature of 290/310°C and keeping in mind the following points:

1. generally much lower temperature for similar cooking times are required than for static ovens.
2. with lower temperatures a better quality and more digestible product is obtained, the oven is not subjected to particular stresses and lasts longer, though the cooking times become longer.
3. with higher temperatures it is more difficult to obtain even cooking but the cooking times are reduced.
4. the oven has a maximum production capacity which is **indicatively** expressed in kg of product per hour. If this production capacity is exceeded, the cooking chamber temperature falls even beyond 10-20°C. If this happens remove the excess quantities and wait for the temperature to be reached again before next loading the oven.

## 7.3 SHORT PERIODS OF IDLENESS

When there are no products to bake, but you want to keep the temperature, it is advisable to low the power regulators in minimum position. In this way, specially if the selected temperature is over 300°C., it is possible that the chamber temperature slightly decreases, but very slowly. This is not a problem, as turning again the power regulators in maximum position, in a short time the oven will reach again the selected temperature and it will be possible to bake the products again.

## 7.4 EXTENDED PERIODS OF IDLENESS

When the oven is not used for a long period, you must position the switches ON/OFF in off position. For longer periods of inactivity (for instance holidays closure) it is advisable to turn off the main switch on the electric panel, but only when the chamber's fans have stopped.

## 8. CLEANING

 Cleaning should be carried out with the equipment switched off and at room temperature and after having switched off its electrical supply with the button on the feed panel.

### 8.1 CLEANING OF ANY REMOVABLE PARTS

 After washing any removable parts it is also necessary to use a water jet on the points at which they connect with the equipment and the corresponding supports so as to prevent the accumulation of dirt or detergent residues which could contaminate the products.

 It is also not advisable to use abrasives (abrasives sponges and such like) as they may in the long term diminish the shine of stainless steel parts and of glass. It is better to wash the various removable parts before the food residues are dry.

### 8.2 CLEANING OF EXTERNAL PARTS

Use a soft wet sponge with a light not abrasive detergent, to clean the stainless steel or painted external parts and the control panels.

 Do not use abrasive or corrosive detergents, as they would damage the stainless steel and the painted parts.

 Do not use jets of water, as they could penetrate the switchboard and create a danger of electrocution and/or sudden start-up of the equipment.

### 8.3 CLEANING OF BAKING CHAMBER

To clean backing chambers in stainless steel, follow the instructions below 9.2.

To reach the inside parts of the backing chamber, first of all switch off the oven, then operate as follows.

Remove the inlet "25" and exit "26" drawer from the conveyor frame "38".

Remove the fixed enclosure "11", moving it upwards.

Turn manually the conveyor until the shaft pin “34” coincides with the joint notch “40”.

Unloose first the counter nut and then the joint fixing screw, using a 10 key; let the joint slide towards the conveyor bench “41” disengaging the joint parts.

Lift up the entry and exit lower diffusers “24” at max. opening.

Lift up the conveyor bench “38” from both sides and move it towards the control side.

Open the serigraph. panel “1” and, using a pair of strong gloves to avoid accidents, disengage the diffusers “3” and “19” from the supports which are near the door, turning upwards; then bring the diffusers towards the centre of the door and remove it; use a 10 key to unscrew the nuts.

To clean the disassembled parts see chapter 9.1; to clean the backing chamber inside, remove the accumulation of dirt with a burst and a dustpan or use a vacuum cleaner; clean the metal surfaces with a sponge steeped in water or non abrasive - corrosive detergents then rinse the surfaces with a damp sponge.

At the end of cleaning remount all the components in opposite sequence to the above mentioned description.

It is advisable to clean the backing chamber every 200 operating hours.

## 9. MAINTENANCE

 **WARNING:** these use and maintenance instructions are intended only for a staff qualified for the installation and maintenance of electrical and gas equipment. Maintenance by other persons may cause damage to the equipment, persons, animals or things.

 In the majority of cases it is necessary to remove the fixed guards in order to carry out repairs and checks. This also renders the voltage cables accessible.

**Before carrying out any maintenance operations check that the equipment's feed cable plug is disconnected from the switchboard. Put the plug in a place where the maintenance operator can easily ascertain, during all of the work done with the guards removed, that it has been disconnected.**

### 9.1 ERROR WARNING

Electronic controls is able to identify some malfunctions, for details see paragraphs 6.6.

### 9.2 SAFETY THERMOSTAT

The safety thermostat intervenes when the temperature in the chamber goes above 500°C and de-activates the resistors. The safety thermostat is located on the outside of the switchboard under the conveyor belt.

To correct the error unplug the feed panel and wait for the chamber to cool down. Unscrew the cap of the safety thermostat reset button and press the button. Resetting is not possible until the temperature in the chamber has fallen below 500°C.

Since the safety thermostat only intervenes where there are serious malfunctions, carefully check the oven's working and repair if necessary before starting up the oven again.

### 9.3 REPLACE BATTERY

The alarm message "BATTERY" has to be referred to the buffer battery of the electronic base board, which is over and must be replaced.

The message on the display is given together with an alarm, which intermittently sounds.

Switch off the alarm sound by pressing the key .

For replacing the battery it is necessary to remove the fixed guards on the electric panel.

 Before carrying out any maintenance operations check that the main cable plug is disconnected from the power.

The battery is located in the middle of the electronic base board, see fig. 8.1; for replacing the battery, please follow carefully the steps listed below:

- switch off the oven and disconnect it from the main power;
- remove the guards of the electronic panel;
- replace the old battery with a new one;
- connect the oven to the power and switch it on;
- set the current time (see paragraph 5.4.1);
- switch off the oven again and disconnect it from the main power;
- connect the oven to the power and switch it on again.

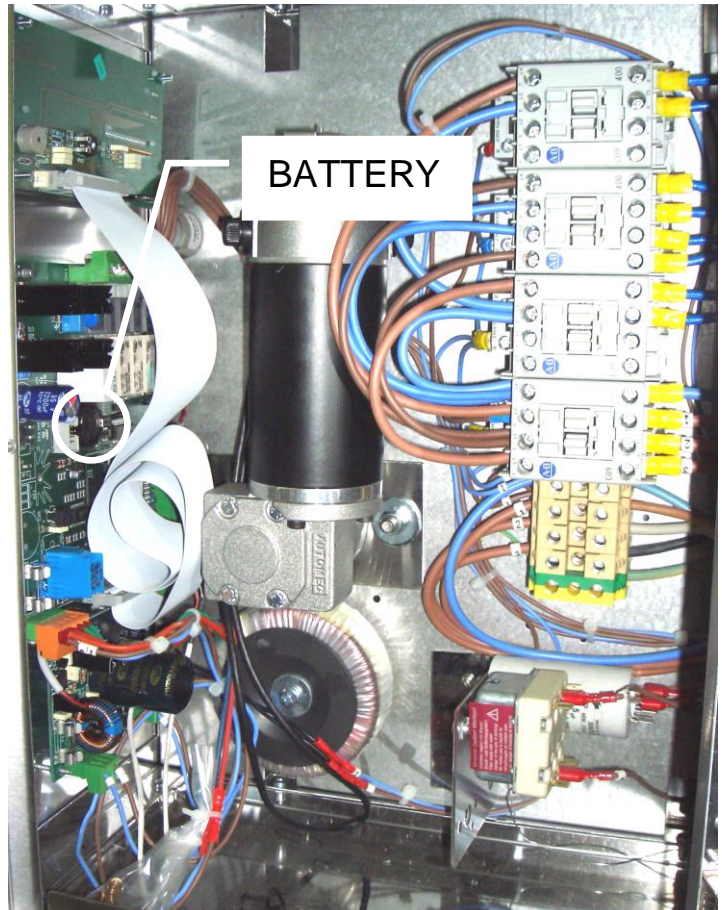

Fig. 8.1 Electronic panel, position of the BATTERY.

Now everything is ok, your battery won't give any other alarm; and you can start working.

In case the "BATTERY" alarm still remains after replacing the battery, please don't forget to set the clock of the base board (see paragraph 5.4.1). Then disconnect the oven from the main power and connect it again.

This operation permits to reset the base board and delete any other alarms in memory.

## 9.4 WIRING DIAGRAM

Figures 10-2, shows the wiring diagram of the conveyor oven mod. Synthesis 12/100V - 400V 3+N.

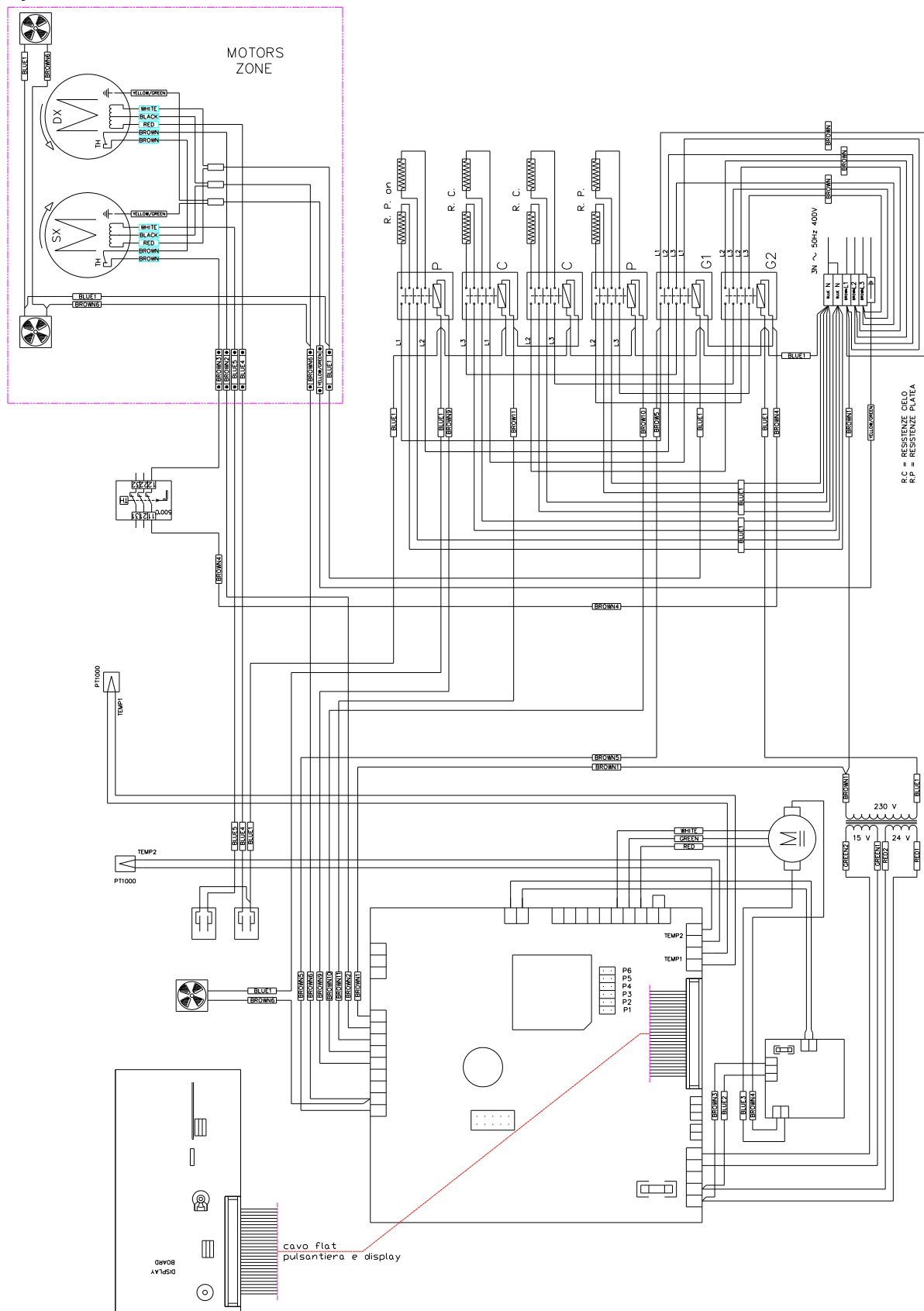

Fig. 10-2 Wiring diagram Synthesis 12/100 - 400 Vac. ~ 3+N 50-60Hz

## **9.4 EXPLODED VIEWS AND LIST OF SPARE PARTS**

For more complicated work and where there are breakages we ask you to please contact us. To simplify the breakdown search and any necessary replacements of damaged parts we give a list, here below of spare parts and exploded diagrams showing each of the listed parts.

The reference figure are Fig. 10-3, Fig. 10-4, Fig. 10-5.

## TABLES OF REFERENCE CODES

<b>POS</b>	<b>DESCRIPTION</b>	<b>CODE</b>
1	Door handle	MANI0057
2A	Top Heating element	RESI0110
2B	Bottom heating element	RESI0110
3	Fan primary	VENT0015
4	Fan cooling	VENT0012
5	Fan motor 50Hz	MOTO0030
	Fan motor 60Hz	MOTO0076
6	Conveyor motor (Transtecno)	MOTO0052
	Conveyor motor (Automec)	MOTO0004
7	Baking tin frame conveyor exit /Baking tin frame conveyor input	CARP1229
8	Upper diffuser dx / Lower sx	CARP1479
9	Lower diffuser dx / Upper sx	CARP1480
10	Right staff	SUPP0028
11	Door frame	PORT0224
12	Door bush	BOCC0006
13	Right door spring	SPRI0010
14	Internal door	PORT0062
15	Glass door	CRIS0025
16	Door spring cover	PORT0065
17	Door holder	CARP0110
18	Rubber washer for external glass	GUAR0051
19	Screw for external glass support	CARP1871
20	Door external glass	CRIS0077
21	Door external glass frame	CARP1909
22	Left door spring	SPRI0009
23	External door	PORT0402
24	Coupling for external glass support	CARP1870
25	Left staff	SUPP0027
26	Bush shaft loose	BOCC0013
27	Journal loose	MECC0523
28	Tube shaft loose	MECC0522
29	Spacer	MECC0520
30	Cogwheel	MECC0519
31	Conveyor	RETE0013
32	Conveyor bearing	CUSC0022
33	Shaft tow	MECC0684
34	Conveyor Joint hub	MECC0114



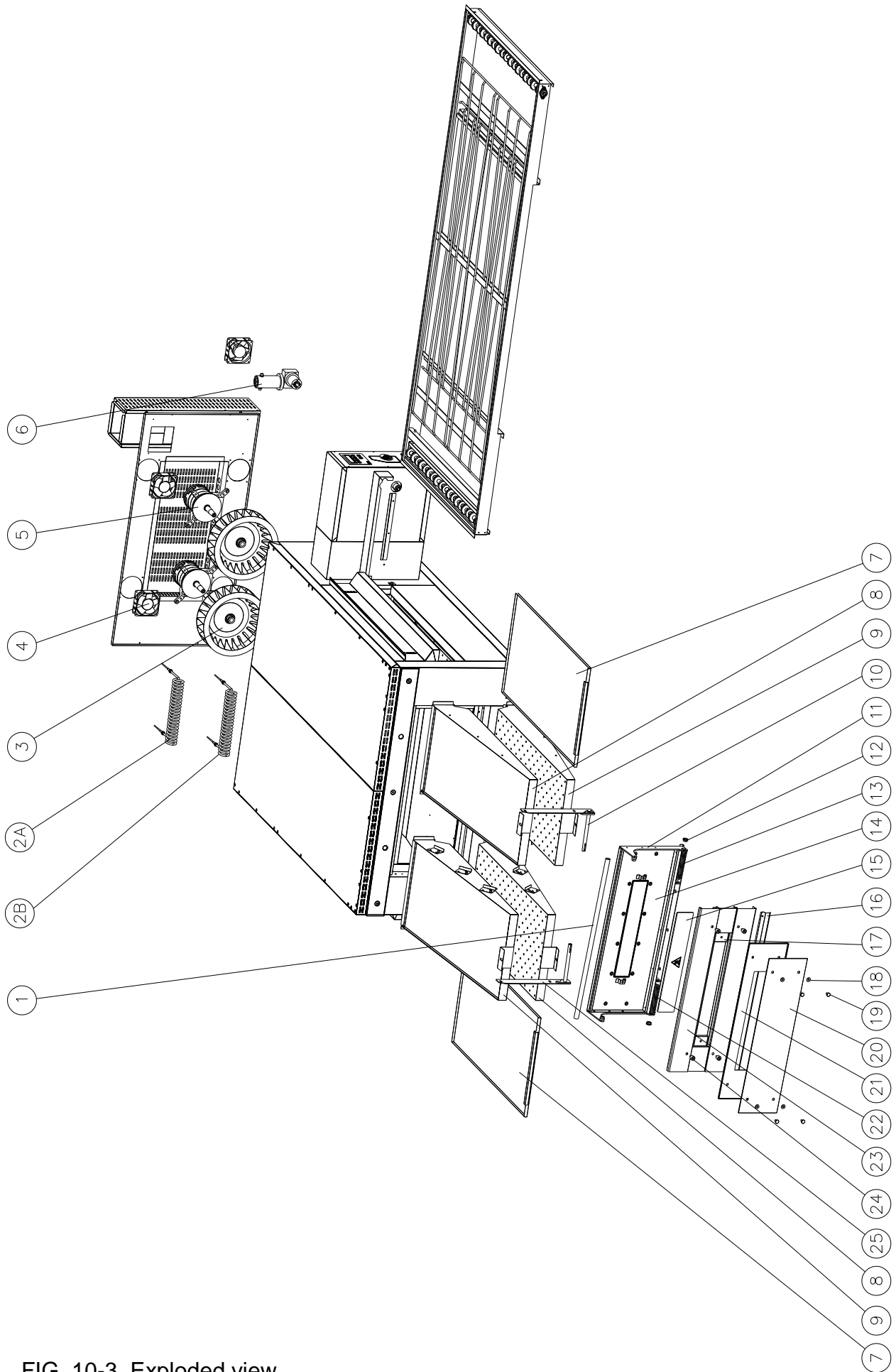

FIG. 10-3 Exploded view

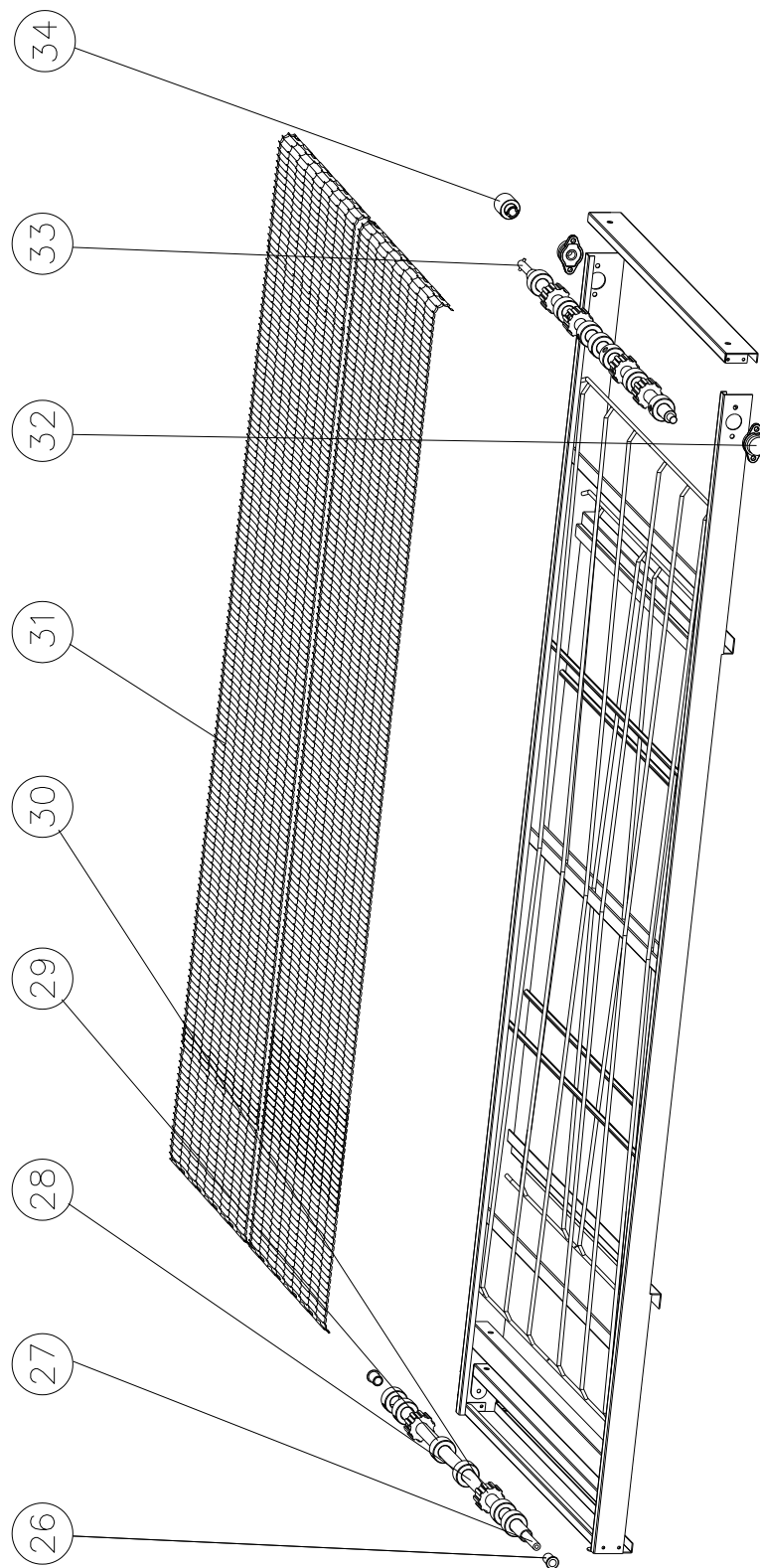

FIG. 10-4 Exploded view of conveyor belt

**SPARE PARTS LIST FOR ELECTRIC COMPONENTS**

<b>POS</b>	<b>DESCRIPTION</b>	<b>CODE</b>
<b>1</b>	<b>Serigraph Panel</b>	PANN0253
<b>2</b>	<b>Display Card</b>	ELET0155
<b>3</b>	<b>Motor Control Card</b>	ELET0213
<b>4</b>	<b>Capacitor</b>	ELET0350
<b>5</b>	<b>Relay switch</b>	ELET0002
		ELET0160
		ELET0432
<b>6</b>	<b>Grey terminal 35mmq</b>	ELET0049
<b>7</b>	<b>Earth terminal 35mmq</b>	ELET0054
<b>8</b>	<b>Probe PT 1000</b>	TERM0049
<b>9</b>	<b>Keyboard</b>	ELET0165
<b>10</b>	<b>Master card</b>	ELET0212
<b>11</b>	<b>Toroidal Transformer</b>	ELET0156
<b>12</b>	<b>Safety Thermostat</b>	TERM0005

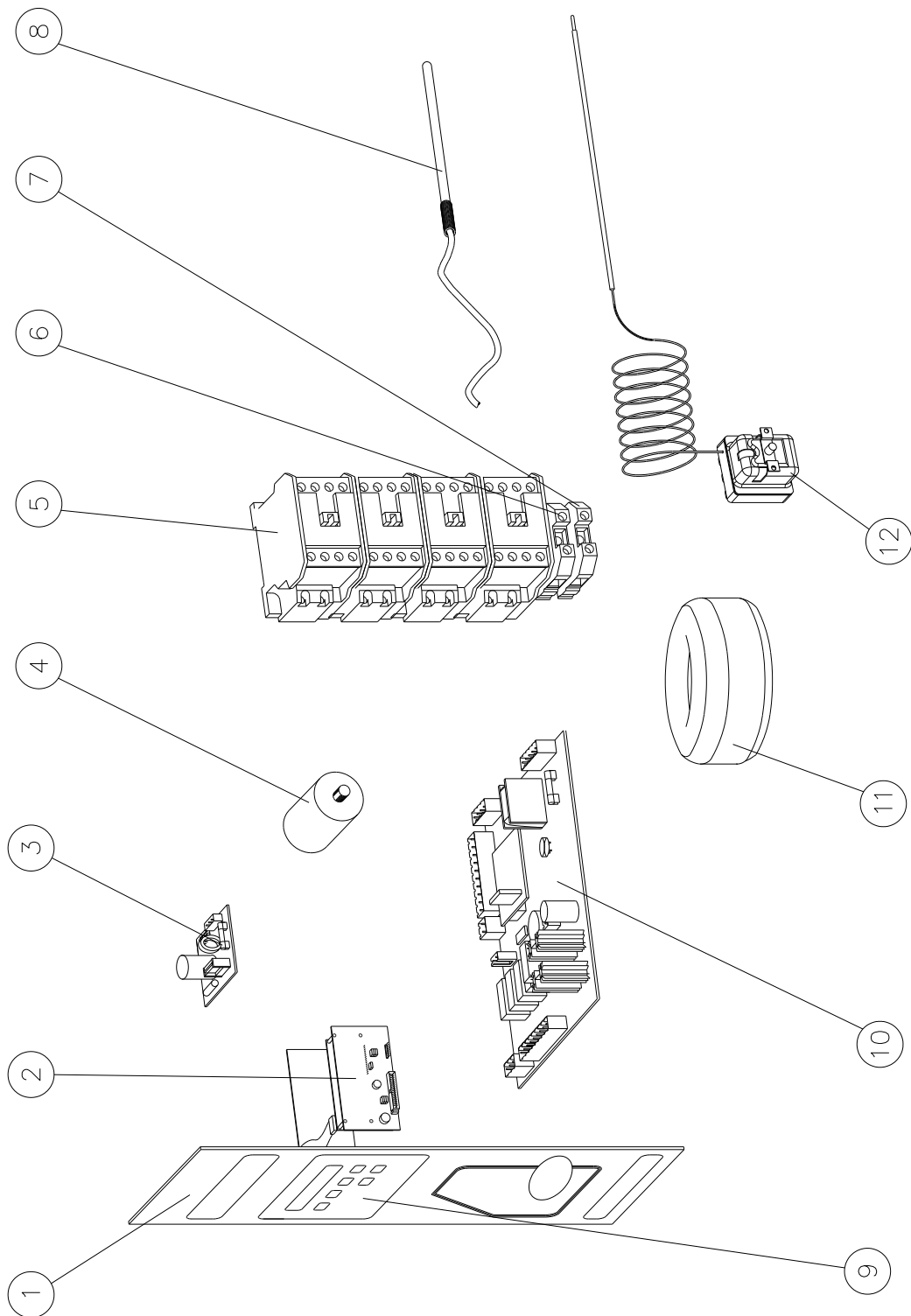

FIG. 10-5 Electrical parts exploded view

## 10. DECOMISSIONING AND DEMOLITION

Before proceeding with the decommissioning disconnect the electrical supplies to the equipment and any other connections there may be and then move the modules using suitable means such as: forklift trucks, hoists, and so on.

The ovens are made up of the following materials: stainless steel, coated steel, glass, ceramic material, rock wool and electrical parts.

For the purposes of demolition therefore the materials have to be separated in observance with the norms in force in the place where the machine is being dismantled.

In any case do not dispose of into the environment.

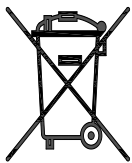

**Separate collection. This product must not be disposed of with normal household waste. Local regulations may provide for separate collection of this kind of product.**